

## SilverNugget N2 I-Grade

The SilverNugget is a servo controller/driver for NEMA 17 & 23 frame microstep motors.



## System Overview

### Special Functions

- Electronic Gearing/Caming
- 100:1 Inertial Mismatch
- Anti-Hunt™: Eliminates servo dither.
- Multi-Tasking (Run Programs During Motions)
- Position & Velocity Using Analog Input
- Variable Torque Brake (Eliminates Slip Clutches)

### Memory Size

- Program Buffer: 200 words
- Non-Volatile: 32K bytes  
Thousands of program lines and data storage.

### Analog Inputs

- 4 Inputs (0 To +5 Volts)
- Continuous And Single Readings
- Can Be Used For Motion Control

### Digital I/O

- 7 I/O Lines (All TTL Level)
- I/O Can Be Programmed For Input Or Output

### Servo Cycle Rate

- 120 microseconds = 8.33 kHz

### Maximum Rotational Speed

- 4000 RPM

### General Commands

- Conditional Jumps
- Wait On Inputs
- Delay Timer
- Program Call And Return
- Math Functions: Add, Sub, Mult, Div
- Logic Functions: AND, OR, XOR
- Storing And Loading User Data
- Load And Run Other Programs

### Motion Commands

- Move Relative And Absolute
- Linear & S-Curve Acceleration & Deceleration
- Velocity Mode
- Torque Mode
- Step And Direction Input
- Complex Profiles (Change Position, Velocity, Acceleration Or Deceleration On The Fly)

### Initialization Commands

- RS-232 Or RS-485
- Serial Baud Rate
- Address Number For Network Operation
- All Digital I/O As Inputs or Outputs
- Servo Control Constants
- Torque Limits
- Motor Shutdown Conditions & Recovery
- Input Voltage
- Over Voltage & Under Voltage Detection
- Over Temperature
- Error Limits
- End of Travel Limits
- Multi-Tasking Enable/Disable
- Driver Enable/Disable

### Read Status & Info Commands

- Errors Conditions
- Internal Conditions
- I/O States
- Data Registers
- Position, Velocity, Target Etc.

## Electrical Specifications

### Input Power

#### Voltage

+12 VDC to +48 VDC, regulated. Devices must be initialized for the actual operating voltage.

#### Over-Voltage Protection

None available. Voltages exceeding +55 VDC will permanently damage the controller/driver electronics. Supply inputs may require active voltage clamping for aggressive braking/deceleration motions or applications with high inertial loads. See the Voltage Clamp Module technical document, (QCI-TD017), for more information on the voltage clamp.

#### Reverse Polarity Protection

None available. Connecting supply voltage in reverse can damage controller and the driver circuitry. However, limiting the supply current externally, to 5 Amps or less, will greatly minimize the chance of hardware failure.

#### Input Current

4 Amps maximum for any input voltage, +12 VDC to +48 VDC.

### Output Power

#### Output/Driver Current

3.5 Amps continuous per phase \*; 4.5 Amps peak per phase \*.

\* With Adequate Heat Sink.

#### Maximum Output Power

150 Watts continuous power with adequate heat dissipation.

### Encoder Interface

#### Primary Encoder Resolutions

2000 Lines = 8000 counts/revolution

Designed to work exclusively with QCI's I-Grade motor/encoders.

## Inputs & Outputs

### Digital Inputs

0 or +5 VDC. TTL level only. Active low (sinking).

Inputs 1, 2 and, 3 have internal 4.7K ohm pull-up resistors to the +5 V.

Inputs 4, 5, 6, and 7 have an effective internal 200K ohm impedance to +5 V.

### Digital Output Voltage

0 or +5 VDC. TTL level only

### Digital Output Current

Sinking or Sourcing

All 7 I/Os 5 mA MAX

### I/O Over-Voltage Protection

Each I/O line is double protected with parallel MOV clamping devices followed by series over-voltage limiting.

### External (Secondary) Encoder Maximum Bandwidth

1 million counts per second

### Analog Inputs

0 to +5.0 VDC input signal range.

10 bit ADC resolution (single).

11 bit ADC resolution (differential).

Analog inputs 1 to 4 are mapped to share digital I/O lines 4 to 7.

Each input has an effective internal 200K ohm impedance to +5 VDC.

Analog signals are read every servo cycle (120  $\mu$ sec.) and the converted analog data is processed through a 5 ms filter to reduce noise & transients.

## Communications

### Hardware Interfaces

RS-232, RS-232 multi-drop, or RS-485 multi-drop (software selectable).

**Protocols:** 8-bit ASCII, 9-bit binary, or Modbus®

### Communication Line Protection

Each line have MOV clamping devices for protection.

### Hardware Configuration Settings

Available Baud Rates: 2400, 4800, 9600, 19.2k, 28.8k, 57.6k, 115.2k or 230.4k

Data Bits: 8

Stop Bits: 1.5 or 2

Parity Bit: None

## Connector Data

### SilverLode Multi-Function Interface (SMI) Port (P1)

The SMI port is a DB15HD (pin) connector containing input power, I/O and communications. Any QCI breakout with an SMI port can be connected to this port via an SMI cable (QCI-EC-SMI-nn). Alternately, the Basic Breakout (QCI-BO-B) attaches directly to the SMI port (no cable).

### Motor Interface Connector (P2)

The Motor Interface Connector is a DB15HD (socket) connector that carries the motor driver signals and the encoder feedback signals. P2 connects to a QuickSilver NEMA 17 or 23 frame QuickSilver's I-Grade Motor/Encoder via a Motor Interface Cable (QCI-C-D15P-D15S-nn , nn=length).

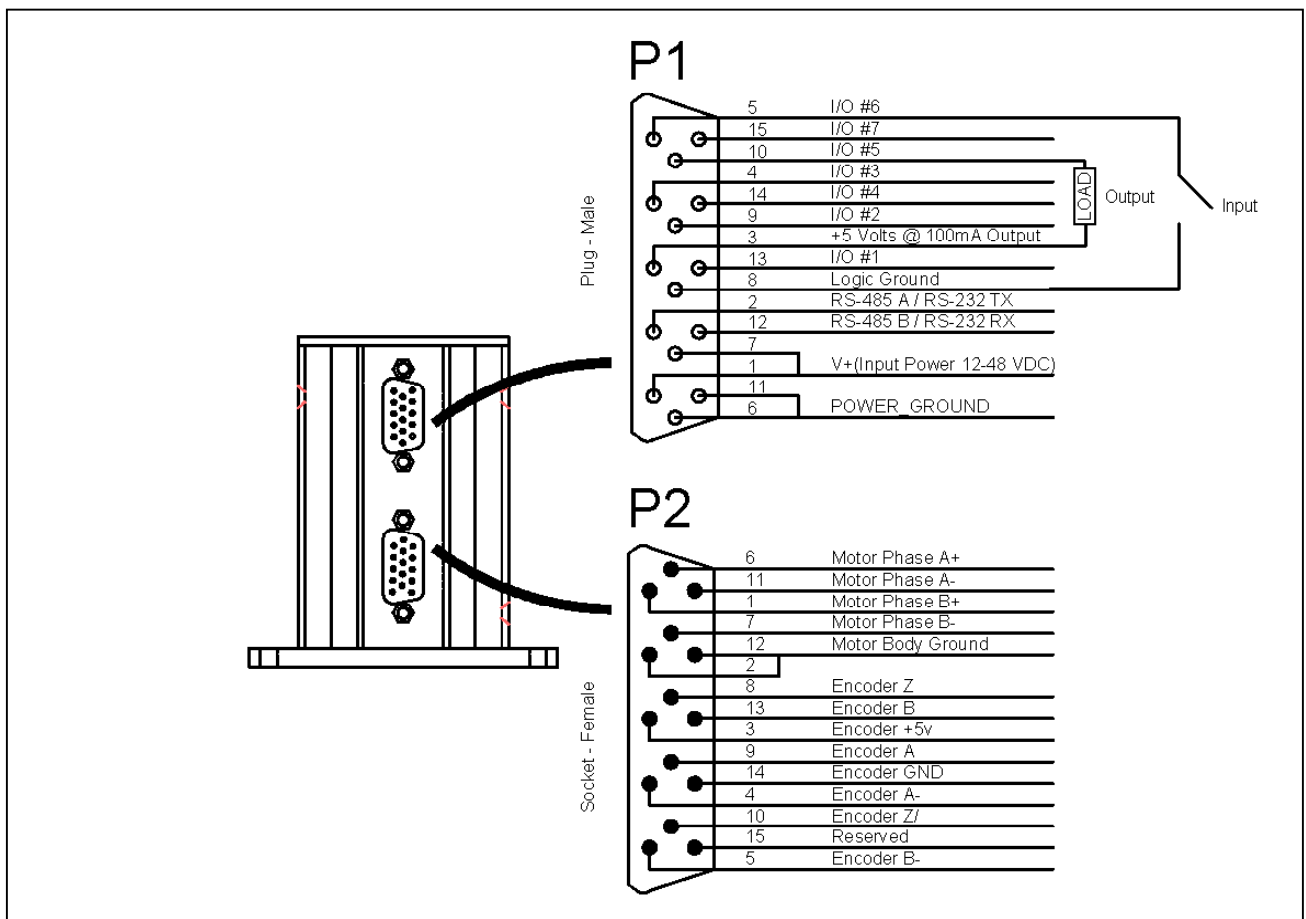

#### P1 Signal Comments:

- +V Input Power and Power Ground lines 1, 7, 6, and 11 are not reverse bias protected.
- I/O lines 1, 2, and 3 each has a 4.7k Ohm pull-up resistor connected to the internal +5 VDC 100mA power supply.
- I/O lines 4 thru 7 each have a 200k-Ohm effective pull-up impedance to the internal +5 VDC power supply.
- All Grounds are tied common to the case.

#### P2 Signal Comments:

- All motor phase signals are 12-48 volts depending on voltage supply inputs.
- All encoder related signals are TTL levels.

## Mechanical Specifications

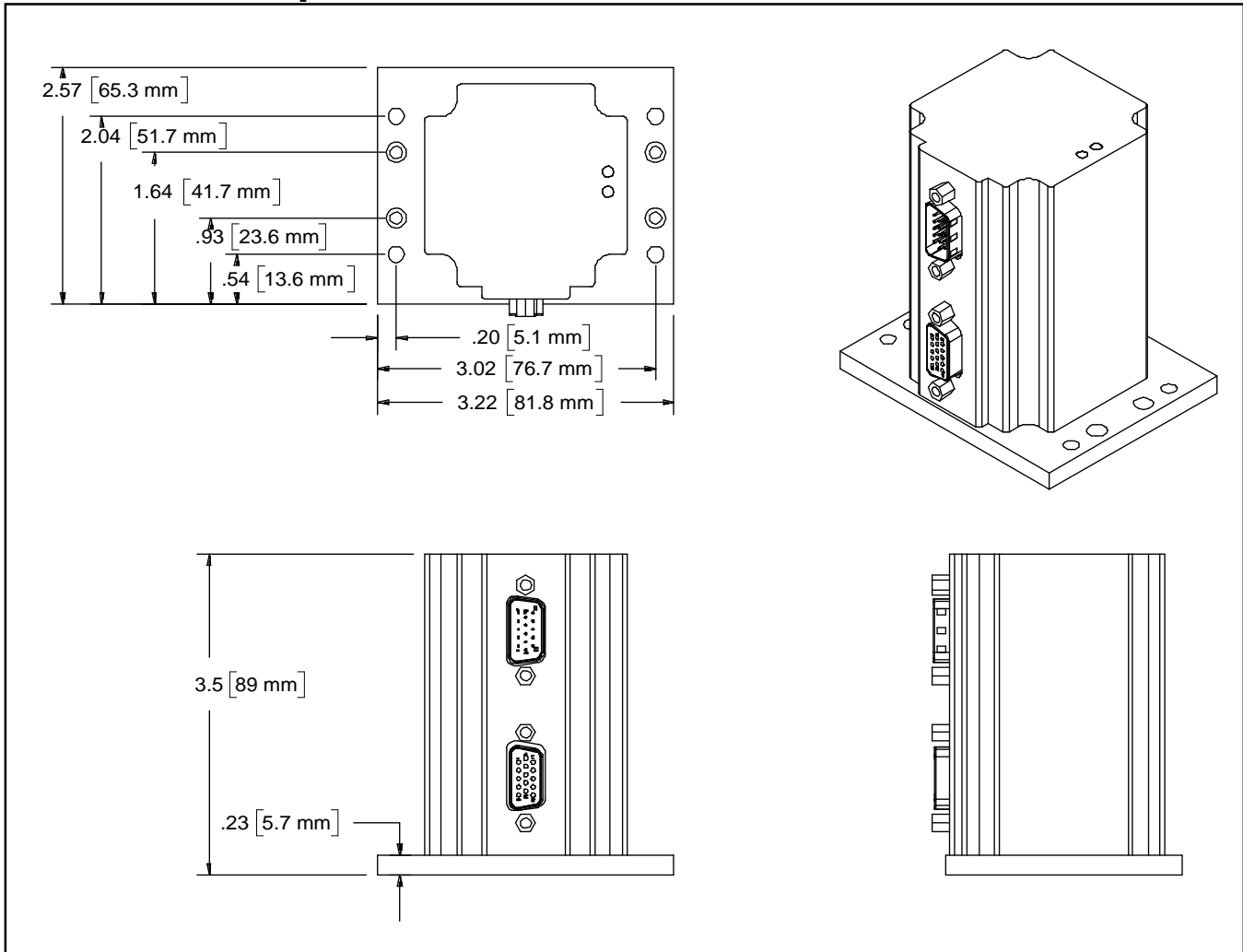

Note: See our website for 2D drawings and 3D models.

## Environmental Specifications

### Operational Temperature

-10 C to +80 C

### Storage Temperature

- 40 C to +85 C

### Humidity

Continuous specification is 95% RH non-condensing.

### Shock

Limitation is approximately 50g/11ms.

### IP Rating

IP50 with cables attached.

QuickSilver Controls, Inc.

## Recommended Components

### Start-Up Kit

For first time users, QCI recommends purchasing the QCI-SKB-N2 Start-Up Kit which includes:

- SilverNugget N2 (QCI-N2-E3-04-EE) & Datasheet (QCI-DS005)
- QuickControl Software CD (QCI-QC)
- User Manual & Command Reference (QCI-SLM)
- Basic Breakout Module (QCI-BO-B) & Tech Doc (QCI-TD036)
- Communication Cable (QCI-C-D9M9F-6)
- 4' DB15HD Motor I/F Cable (QCI-C-D15P-D15S-4)
- Start-Up Kit Setup Instructions (QCI-TD042)

With this Start-Up kit, a power supply, and a motor/encoder, you will have everything you need to get started. See technical document QCI-TD042 on our website for details.

The Standard System detailed below uses the QCI-SKB-N2.

### Typical System Setup:

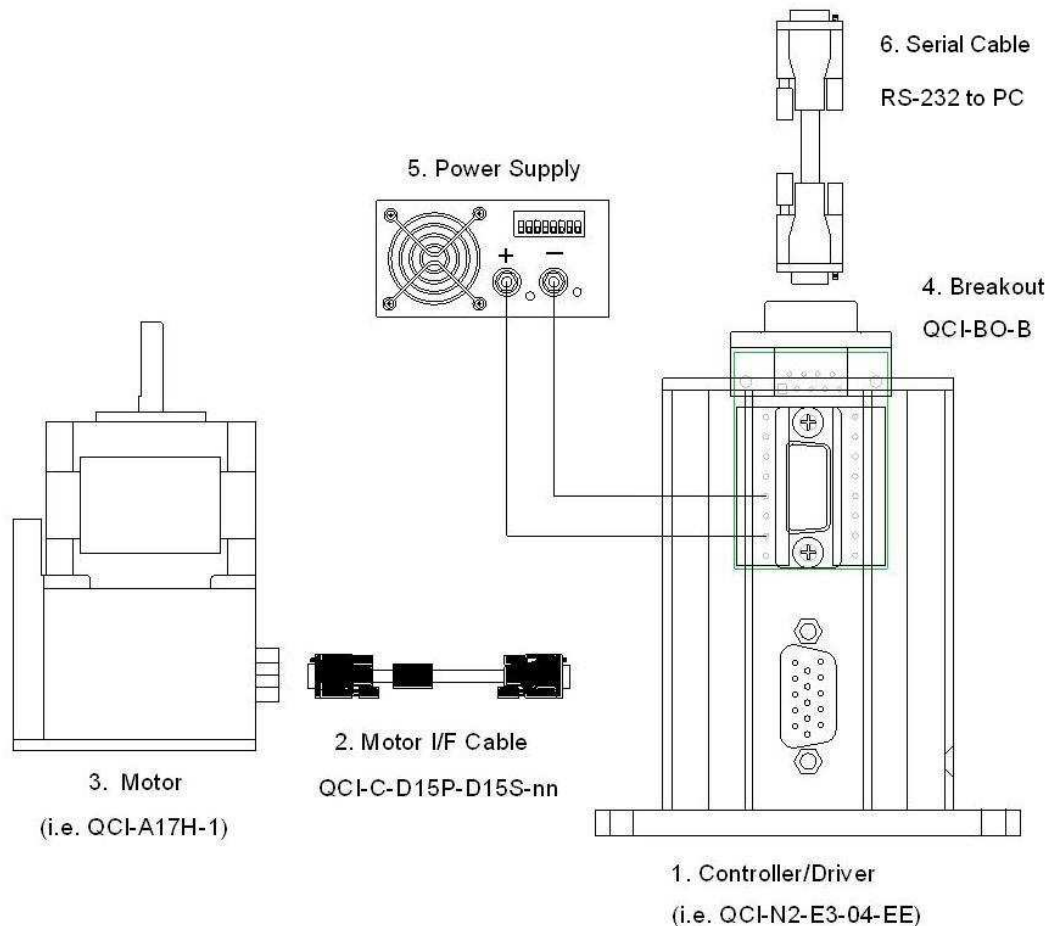

**IP65 System**

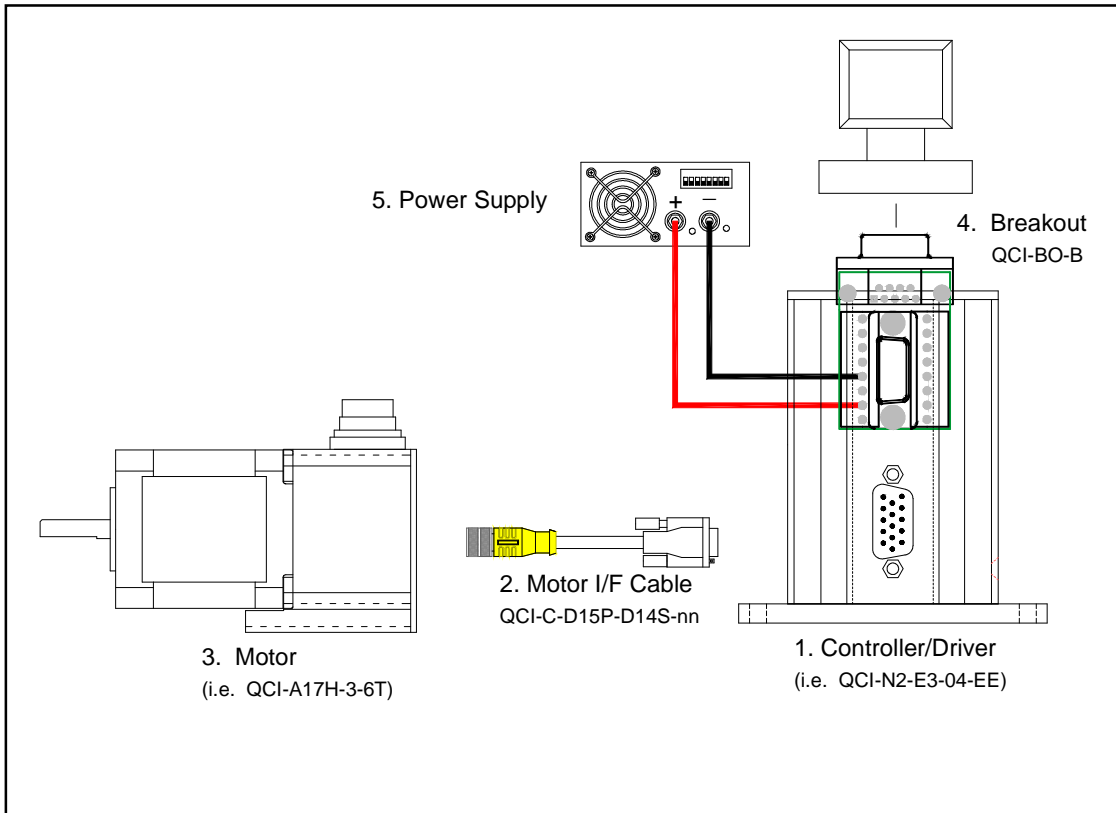

**1. Controller/Driver**

The standard controller driver is QCI-N2-E3-04-EE. All other options are application dependent.

**2. Motor I/F Cable**

For standard system, D-sub type cable goes between the motor and the controller. The generic part number is QCI-C-D15P-D15S-nn. Replace the last two digits “nn” with length of cable in feet (i.e. –10 for 10 feet). Standard stock lengths are 1, 4, and 10 feet.

For IP65 system, a special IP65 cable goes in between the motor and the controller. The motors and cables are IP65, but not the controller/driver. The generic part number is QCI-C-D15P-T14S-nn. Replace the last two digits “nn” with length of cable in feet (i.e. –10 for 10 feet).

**3. Motor**

The SilverNugget N2 is capable of driving any A 17 or 23 I-Grade motor/encoder. See the following datasheets for more information:

QCI-DS007: NEMA 17 I-Grade Motor/Encoder

QCI-DS008: NEMA 23 I-Grade Motor/Encoder



#### **4. Basic Breakout (QCI-BO-B or QCI-BO-B52)**

QCI recommends purchasing a breakout to simplify wiring power, communications and I/O. QuickSilver offers several breakouts (see our website), but the simplest is our Basic Breakout (QCI-BO-B). To convert the 7 TTL I/O to 5 24V isolated inputs and 2 open collector outputs, select the QCI-BO-B52.

#### **5. Power Supply**

Power supply selection is motor dependent, but the following will work with all the 17 and 23 frame motors.

S-210-48 (48V, 4.4A, 210 Watt)

## **Other Recommendations**

#### **SilverLode User Manual & Command Reference (QCI-SLM)**

For beginning and brand new users, please see chapter 1 User Manual for getting started instructions. The SilverLode user manual is in a textbook format. It begins with the fundamentals of use and progresses into advanced topics that are application oriented. Any new user can follow the material in a natural progression of product usage. In addition, there are exercises throughout the text that provide users a hands-on approach toward understanding the topics better. The manual is thorough, but not exhaustive. Users that explore this material fully and complete the exercises should gain the ability to operate, program, and prototype any SilverLode servo system into working applications.

Both the user manual and command reference are available for download on our website. QuickSilver also sell hard copies of the SilverLode User Manual & Command Reference set under part number QCI-SLM.

#### **Clamp Module (optional)**

Some rapid acceleration and deceleration applications may require a clamp module. See technical document QCI-TD017 on our website for more details.

#### **QuickControl Software**

QuickControl® allows developers to quickly program and operate all SilverLode family of products using a standard PC running Windows (9x, Me, NT, 2K, or XP). Communication to the SilverLode controller/driver products is accomplished from the PC's serial port (i.e. COM1 or COM2). QuickControl also provides tools for uploading and downloading programs and user data. Data can be typed in manually or import from text files. Documentation features include remarks, line labels, namable registers and I/Os.

## Part Numbers

SilverNugget™ N2 I-Grade Controller/Drivers			
DRIVER	CONTROLLER	OPTION	MOTOR INTERFACE
<p><b>QCI-N2</b> - 3.5 Amps</p> <ul style="list-style-type: none"> <li>For 23 Frame and Smaller</li> <li>3.5 Amps per Phase Continuous *</li> <li>4.5 Amps Peak</li> </ul> <p>* Depending on heat sink (25C ambient).</p>	<p><b>E3</b>– Standard</p> <ul style="list-style-type: none"> <li>8 bit ASCII or 9 bit binary protocols</li> </ul> <p><b>E7</b> - Driver Enable</p> <p><b>M3, M7</b> – Modbus®</p> <ul style="list-style-type: none"> <li>Same as E3 or E7 except 9 bit binary protocol replaced with Modbus® protocol</li> </ul> <p><b>F2</b> – Same as E3 except incoming encoder is divided by 2 to emulate a 4000CPR encoder</p> <p><b>F7</b> – Same as F2 except with Driver Enable</p>	<p><b>04</b> – I-Grade</p> <ul style="list-style-type: none"> <li>SilverLode Multi-Function Interface (SMI) Port</li> <li>DB15 (socket) I-Grade Interface for encoder signals.</li> </ul>	<p><b>EE</b> - Standard I-Grade Interface for connection to I-Grade Motor / Encoders.</p>
To create a part number, choose one from each column above.			
<b>QCI-N2</b>	<b>E3</b>	<b>04</b>	<b>EE</b>
This selection creates the part number: <b>QCI-N2-E3-04-EE</b>			

## Contact Information

QuickSilver Controls, Inc.  
 712 Arrow Grand Circle  
 Covina, CA 91722  
 (626) 384-4760 or (888) 660-3801  
 (626) 384-4761 FAX  
[www.QuickSilverControls.com](http://www.QuickSilverControls.com)